



Step-by-Step Instructions for iEQ45 R.A. Worm Installation/Replacing

September 2013

These instructions serve to explain how to

- Replace a R.A. worm;
- Adjust a RA worm/wheel meshing;
- Inspect and clean a RA worm.

The procedures are similar for the DEC.

Please read the instructions carefully before working on the mount.

1. Remove iEQ45 main board cover.



2. Remove black R.A. gear box cover by loosening the two screws.



3. Unscrew four screws on the RA motor drive board.

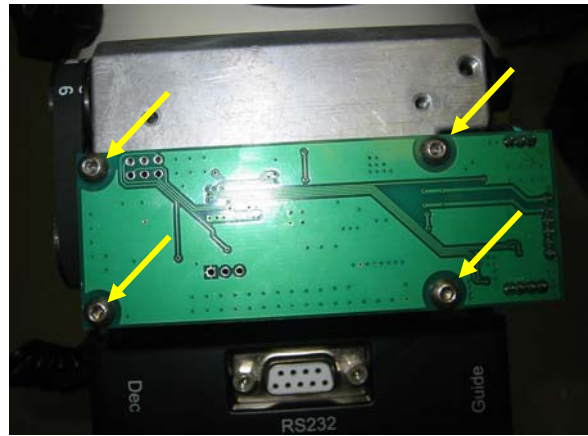

4. Next, remove the belt and two pulleys. First, you will need to turn the wheel so you can insert a 1.5mm hex wrench and loosen the set screw on each pulley. It only needs to be loosened a little. See next photo for direction on disengaging gear to allow the pulleys to turn.

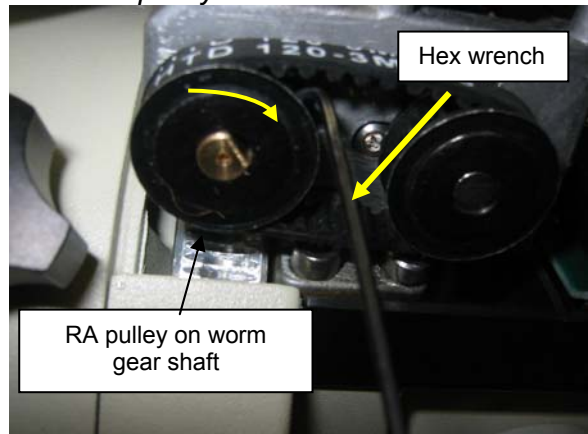

4a. In order to turn the pulleys, you need to partially disengage the worm gear. Make sure the power is turned off. While pushing down on the edge of the RA gear box, turn the RA pulley to access the set screws with a hex wrench.

If the pulleys are very difficult to turn, you can connect the power and turn on the mount. Then turn the pulleys slowly using the hand controller.

Release the set screw on the motor shaft first. Then remove both wheels at the same time.

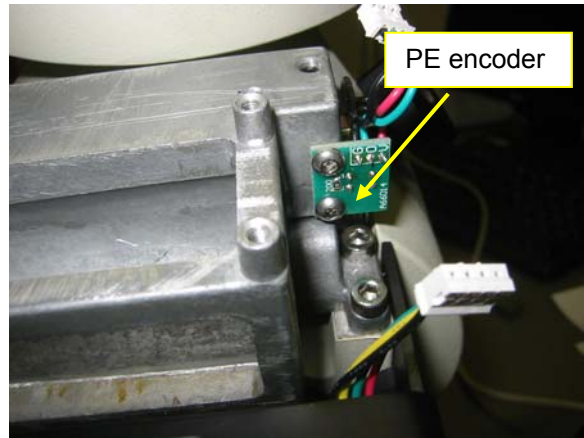
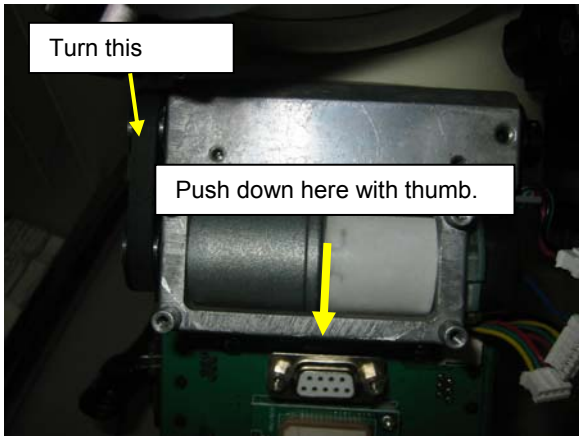

5. Carefully disconnect the 3 sets of cables that are connected to the RA drive board.

8. Remove the four hex screws that hold the RA house in place, which will expose the aluminum RA wheel as shown in the picture below. You may mark the hinges' position before release the screws. Be careful not to lose the spring.

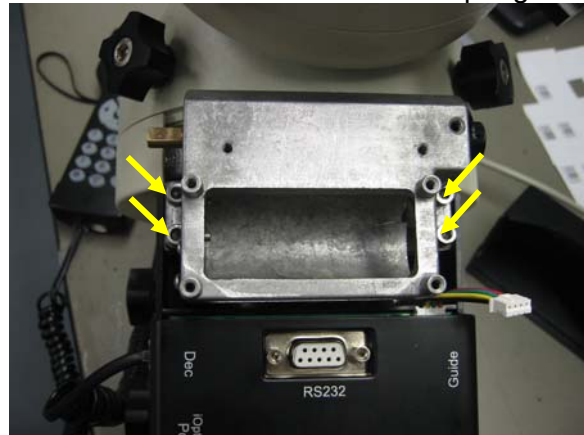
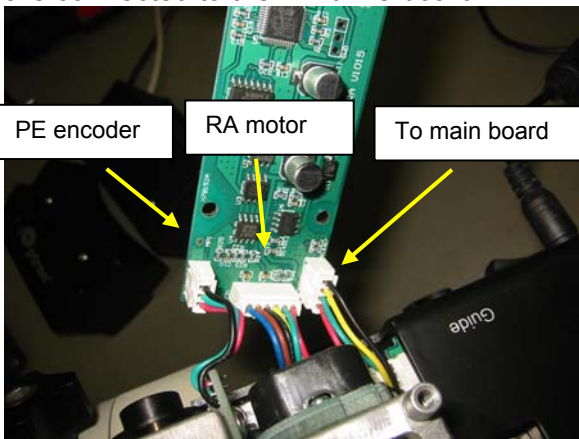

6. Loosen the four screws that secure the motor and remove the motor from the RA worm gear house from the other end.

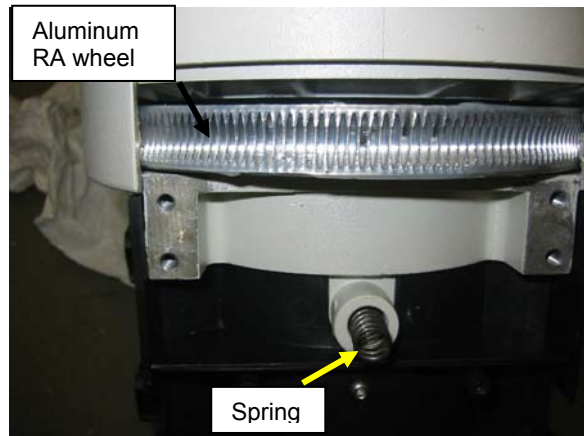

7. Remove the periodic error (PE) reference encoder from the RA house.

9. Remove the hinges (different on each side) from hinge shaft. Be careful not to lose the two copper washes that go with the hinges. Remove the PE encoder wheel from the RA worm shaft by releasing a set screw on the wheel.

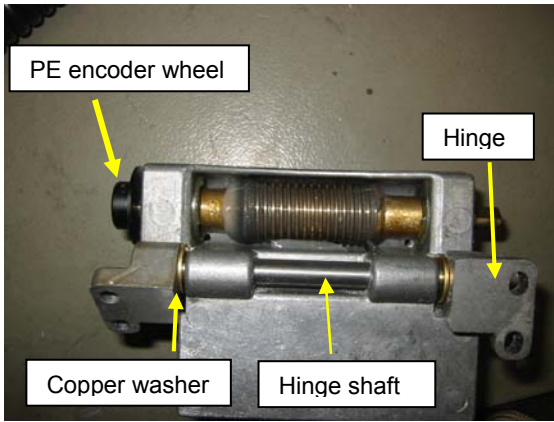

10. Release RA worm end cap set screw.



11. Remove the RA worm end cap. Push the end of the worm.



12. Pull the RA worm and 2 bearings out of the house. Lightly tap the end if needed.



13. Clean the worm house and make sure there is no debris.

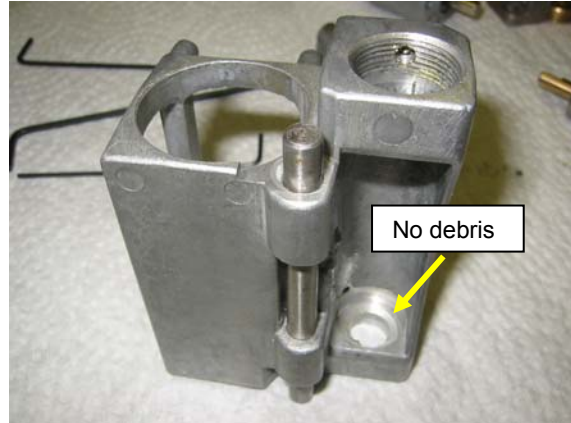

14. Mount two new bearings onto the new worm shaft. Insert the RA worm back into the house and make sure each part is aligned well and there is no lateral play while the worm gear is rotating. Please **do not reverse** the pulley installation side and PE encoder side when inserting the worm into the house.

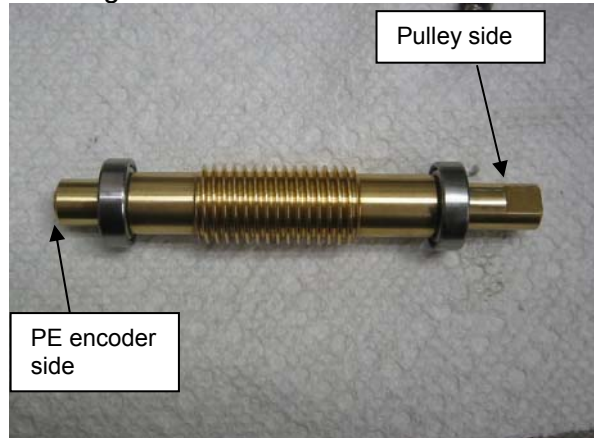

15. Install the end cap. When tightening the end cap, make sure there is no gap between the bearing race and shaft inner edge wall, as indicated in the photo.

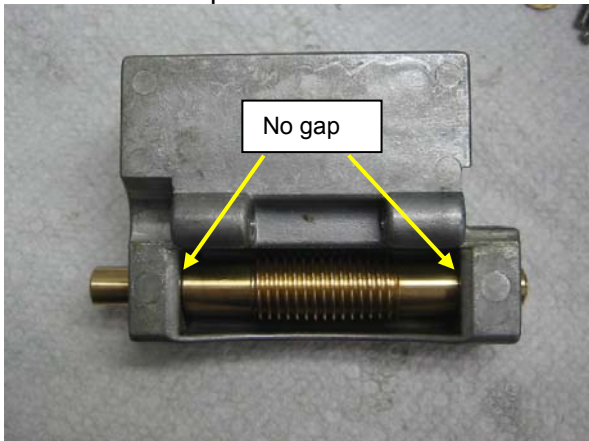

16. After the end cap is fully tightened, release 1/8 to 1/4 turns of the end cap. Turning the worm gear to make sure it turns smoothly and there is no plays introduced while pull the worm end. A little stiffness is OK. Secure the set screw. Apply some grease as needed while assembling.

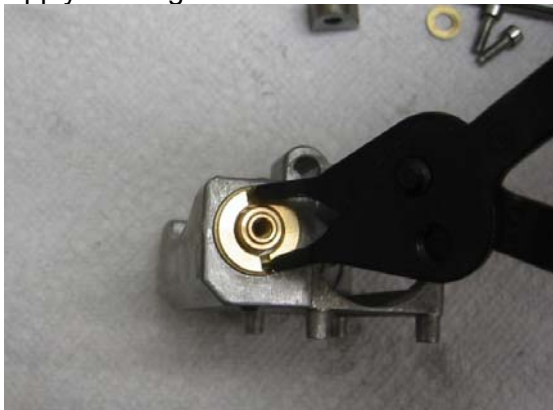

17. Insert the hinge shaft into the RA house. Place the copper washers and hinges back onto the shaft.



18. Now comes the most important part: installing the RA worm gear back into the mount. In factory, there is a fixture to ensure a proper gear mesh between the gear and worm. Since we don't have a fixture, the rule of thumb is that after the RA house is installed, the mount can be turned in RA direction smoothly using your fingers easily while turning the RA shaft. We also suggest checking the RA motor current while it is slewing at the highest speed after the motor and belt are installed. The mount should run very smoothly without any "laboring sound", if it meshes well.

As indicated in Step 8, place the RA house on top of the RA wheel and put the four hex head screws back. Fasten them, but not fully tightened, to secure the RA house. Make sure the spring is properly sitting inside the hole.

Push the two hinges inward to eliminate possible lateral play (1). Push the RA house down and forward to make sure the brass worm gear is sitting on top of the curved center of the aluminum wheel (2). In most cases, we would push the two hinge ends forward while tightening the 4 screws (3). Use the marks that you put on while dismount the RA house as an initial reference.

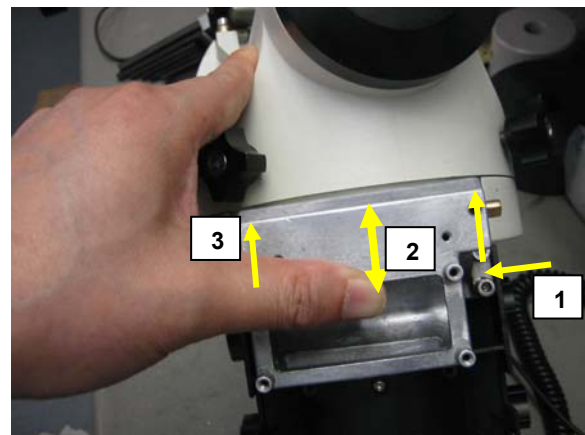

Turn the RA worm gear shaft to rotate the mount along RA axis. It should easily move in both directions. If not, the cage position needs to be adjusted.



19. Install the new PE encoder wheel and board. Then reinstall the RA motor. Tighten the four screws evenly. Install the RA board and connect the cables.



20. Turn the flat surfaces of the motor and worm gear shaft to face each other, so they can be easily accessed with the hex wrench after the wheels and belt are installed (see next step). You may power the mount on to rotate the motor shaft.

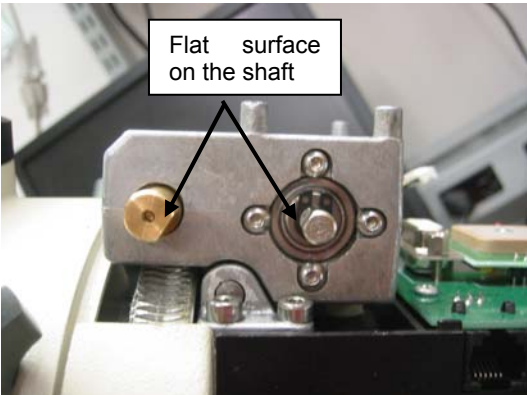

21. Remove the set screws from old RA shaft pulley and install it onto the new one. Adjust the

set screw depth on the pulleys so that the wheel can only slide onto the shaft in one position (see arrow below). Place the belt over the two wheels and arrange them according to the position of two shafts (see flat surfaces on shafts above). After the wheels are placed on the shaft they will not be able to turn freely without turning the motor or worm.

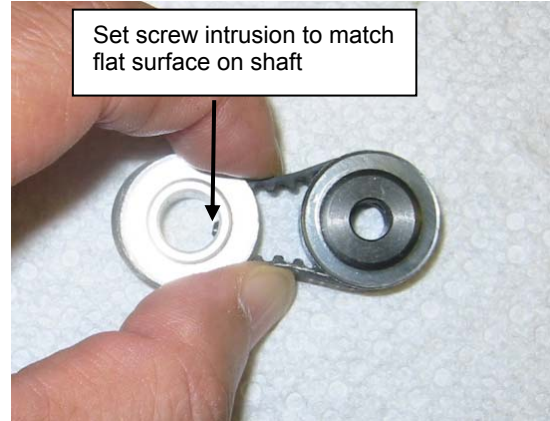

20. Place the pulleys onto the shafts. Push the belt wheel half-way onto the worm gear shaft. Check if the other wheel can freely slide onto the motor shaft and mate to the flat surface. If not, power the mount on, select a slower speed (like 4X or 16X), using the left or right key to turn the motor shaft. Push the belt wheel all the way onto the motor shaft. Then push the other wheel all the way in. Tighten both set screw with a hex wrench. There should be some space between the wheels and the RA gear cage.

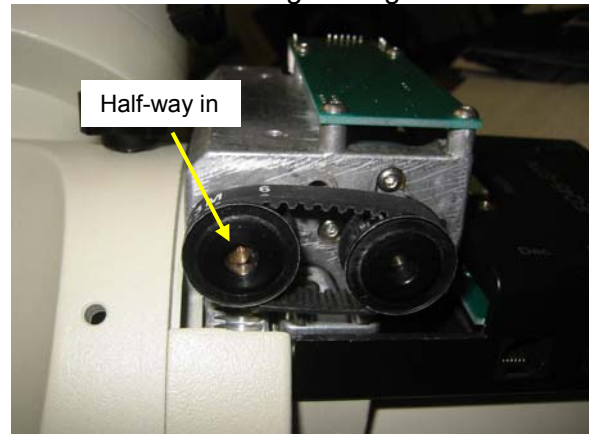

23. Turn the mount in RA direction in full speed to see if the mount is running smooth and well. If a multimeter is used to measure the slew current, it should be less than 600mA while slewing at MAX speed. The smaller the reading, the better worm and wheel mesh. Secure the RA board and replace the cover.