

# Orion® EQ-3M Single-Axis DC Motor Drive System

#7829

Welcome to a new world of adventure. The Orion EQ-3M Single-Axis DC Motor Drive System allows convenient hands-free tracking of the night sky for telescopes that utilize the Orion EQ-3 Equatorial Mount. The motor drive system also features a push-button hand controller that can move the telescope along the R.A. axis at speeds 2x and 8x the sidereal rate. This provides an easy way to center objects in the eyepiece, and also allows for advanced astrophotography with the EQ-3 mount.

## 1. Parts List

- 1 R.A. motor drive assembly
- 1 Hand controller
- 1 Battery pack
- 1 4mm Allen wrench
- 1 2mm Allen wrench

## 2. Installing the R.A. Motor Drive Assembly

1. When facing the front of the mount, the R.A. slow-motion control cable should be mounted to the right end of the R.A. worm gear shaft (Figure 1). If it is mounted on the left end, remove it, and reinstall it on the right end of the shaft.

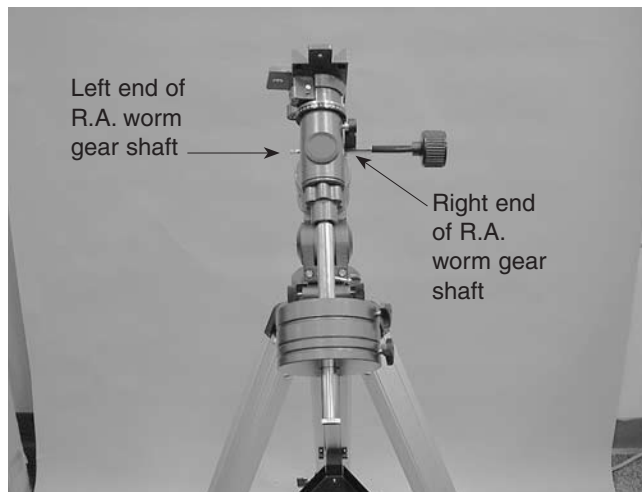

**Figure 1:** The R.A. slow motion control cable needs to be mounted on the right end of the R.A. worm gear shaft.

2. Using the provided 2mm Allen wrench, loosen the socket-head setscrew on the end of the R.A. motor drive coupler (Figure 2).
3. Use the provided 4mm Allen wrench to remove the socket-head screw on the left side of the mount (Figure 3).
4. Orient the motor so that the drive coupler slips over the left end of the R.A. worm gear shaft. Now, attach the motor to the mount by inserting the socket-head screw

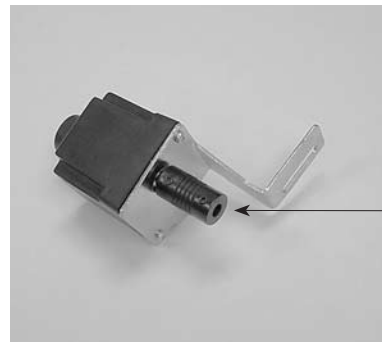

**Figure 2:** Loosen the setscrew on the end of the drive coupler. This is the setscrew that engages and disengages the motor drive.



**Figure 3:** Remove the socket-head screw indicated on the mount.



**Figure 4:** The R.A. motor drive assembly properly connected to the mount.

through the slot in the motor's bracket, and re-threading it into the mount.

5. Tighten the socket-head setscrew on the end of the drive coupler. The setscrew should seat into the groove on the end of the worm gear shaft. You may need to rotate the worm gear, using the R.A. slow-motion control cable, for the setscrew and the groove to line up. You may also need to adjust the drive coupler on the motor's output shaft to position the setscrew over the groove; this is done by loosening the setscrew on the drive coupler that is closest to the motor. Once both setscrews are tightened, the R.A. motor is engaged. When the motor is engaged, never, under any circumstances, should you use the R.A. slow-motion control cable. If you want to use it, first loosen the setscrew on the end of the coupler to disengage the motor drive.

The motor is now properly installed on the EQ-3 mount, and should appear as in Figure 4.

### 3. Operation

Insert four D-cell batteries into the battery pack. Orient the batteries as indicated on the white plastic battery holder. Connect the end of the battery pack's power cord to the DC power input on the hand controller.

There is a white cord that is permanently connected to the hand controller. Connect the plug on the end of the cord to the socket on the R.A. motor drive assembly.

For the motor drive system to track the motion of the night sky properly, the equatorial mount must be polar aligned. This involves aligning the R.A. axis of the mount so it is parallel to the Earth's axis of rotation (polar axis). Consult the manual that came with your equatorial mount for details on how to polar align it. The telescope also must be well balanced on the mount's R.A. axis.

When observing in the Northern Hemisphere, the N/S switch on the hand controller should be in the "N" position. For the Southern Hemisphere, it should be in the "S" position.

Make sure the motor is engaged (i.e. setscrews on the drive coupler are tightened), and turn the power switch on the hand controller to the "ON" position. The LED in the center of the hand controller should be shining green. If properly polar aligned and balanced, the mount will now be tracking the motion of the night sky, and the telescope should hold any astronomical object in its eyepiece steady over time.

To move your telescope to a new object, loosen both the R.A. and Dec. lock levers and move the telescope until it is pointed in the general direction of the object you wish to view. Retighten the R.A. and Dec. lock levers. Now, disengage the motor drive by loosening the setscrew on the end of the drive coupler, and use the R.A. and Dec. slow-motion control cables to center the object in the eyepiece's field of view. Re-engage

the motor by tightening the setscrew, and the motor drive system will keep the object centered over time. Remember, never use the R.A. slow-motion control cable when the motor is engaged or you could permanently damage the motor.

There are four buttons on the hand controller. If no buttons are pressed, the motor will turn the R.A. axis of the mount at sidereal rate. If the bottom right button is pressed, the motor will turn at 2x sidereal rate, which will cause objects viewed in the telescope's eyepiece to move slowly eastward. If the bottom left button is pressed, then the motor will stop turning, which will cause objects in the eyepiece to move slowly westward. The bottom two buttons are most useful for guiding purposes during long-exposure astrophotography.

Similarly, the top right button on the hand controller moves objects in the telescope's eyepiece quickly eastward at 8x the sidereal rate, while the top left button moves objects quickly westward at 8x sidereal. The top two buttons are most useful for centering an object in R.A. within the field-of-view of an eyepiece.

Note that whenever any of the four buttons on the hand controller are pressed, the LED in the center of the hand controller will shine red; when the button is released, the LED will shine green again.

### 4. Specifications

Guiding rate: 2x sidereal, motor pause

Centering rates:  $\pm 8x$  sidereal

Power requirement: 6V DC

Battery type: D-cell, quantity four

Northern or Southern Hemisphere operation

DC stepper motor

## One-Year Limited Warranty

This Orion EQ-3M Dual-Axis DC Motor Drive System is warranted against defects in materials or workmanship for a period of one year from the date of purchase. This warranty is for the benefit of the original retail purchaser only. During this warranty period Orion Telescopes & Binoculars will repair or replace, at Orion's option, any warranted instrument that proves to be defective, provided it is returned postage paid to: Orion Warranty Repair, 89 Hangar Way, Watsonville, CA 95076. If the product is not registered, proof of purchase (such as a copy of the original invoice) is required.

This warranty does not apply if, in Orion's judgment, the instrument has been abused, mishandled, or modified, nor does it apply to normal wear and tear. This warranty gives you specific legal rights, and you may also have other rights, which vary from state to state. For further warranty service information, contact: Customer Service Department, Orion Telescopes & Binoculars, 89 Hangar Way, Watsonville, CA 95076; (800) 676-1343.

 **ORION**<sup>®</sup>  
**TELESCOPES & BINOCULARS**  
*Providing Exceptional Consumer Optical Products Since 1975*

**Customer Support (800) 676-1343**  
**E-mail: support@telescope.com**  
**Corporate Offices (831) 763-7000**  
**89 Hangar Way, Watsonville, CA 95076**